

S675-800 2000 Watt Alternator

Features:

- Brushless Design
- Only one moving part (a sealed ball bearing) when direct driven
- NeFB Magnets
- Humidity and moisture resistant

Model Number	S675-800
Alternator Diameter	203 mm
Alternator Thickness	36 mm
Alternator weight, standard 2000 W 16 pole winding without brackets	3160 g
12 pole 1200W	2930g
Engines	Most engines 240cc and larger
Rated Power at low cruise RPM	2000 watts
Maximum power	3500 watts
Standard Wind Type	Single Phase
No-Load Voltage Curve	12.0 VAC/1000 RPM
Aluminum Spinner	Special order
Options	Special winding Modified shell machining

S675-800
on 3W-342

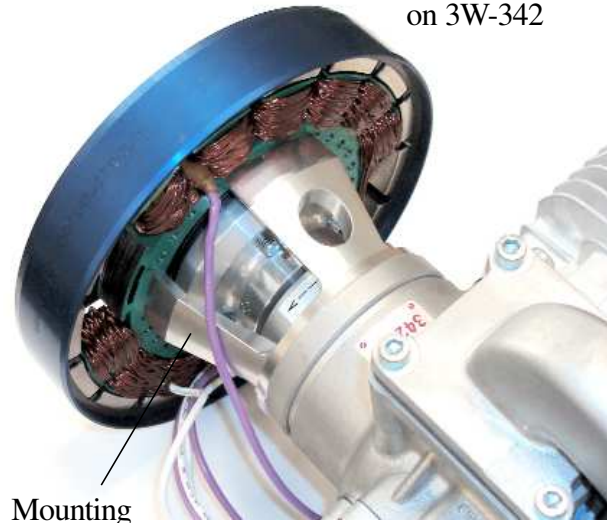

Mounting
Bracket



S675-800
Front

S675-800
Rear

S675-800
on 3W-342



Sullivan

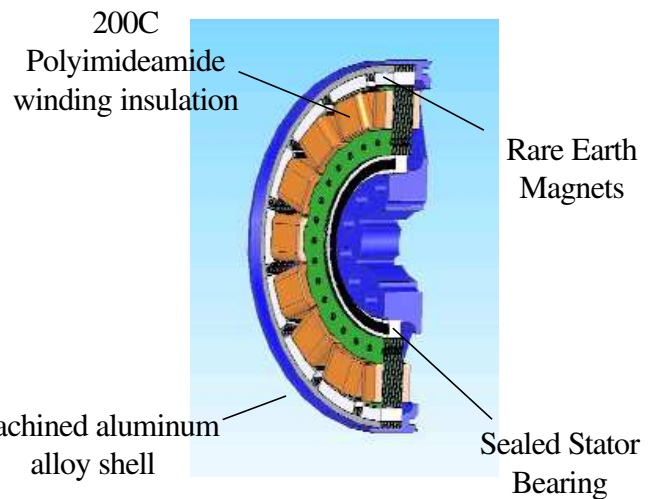

203 mm 12 pole Watts

S675-800
Output
Standard
Winding

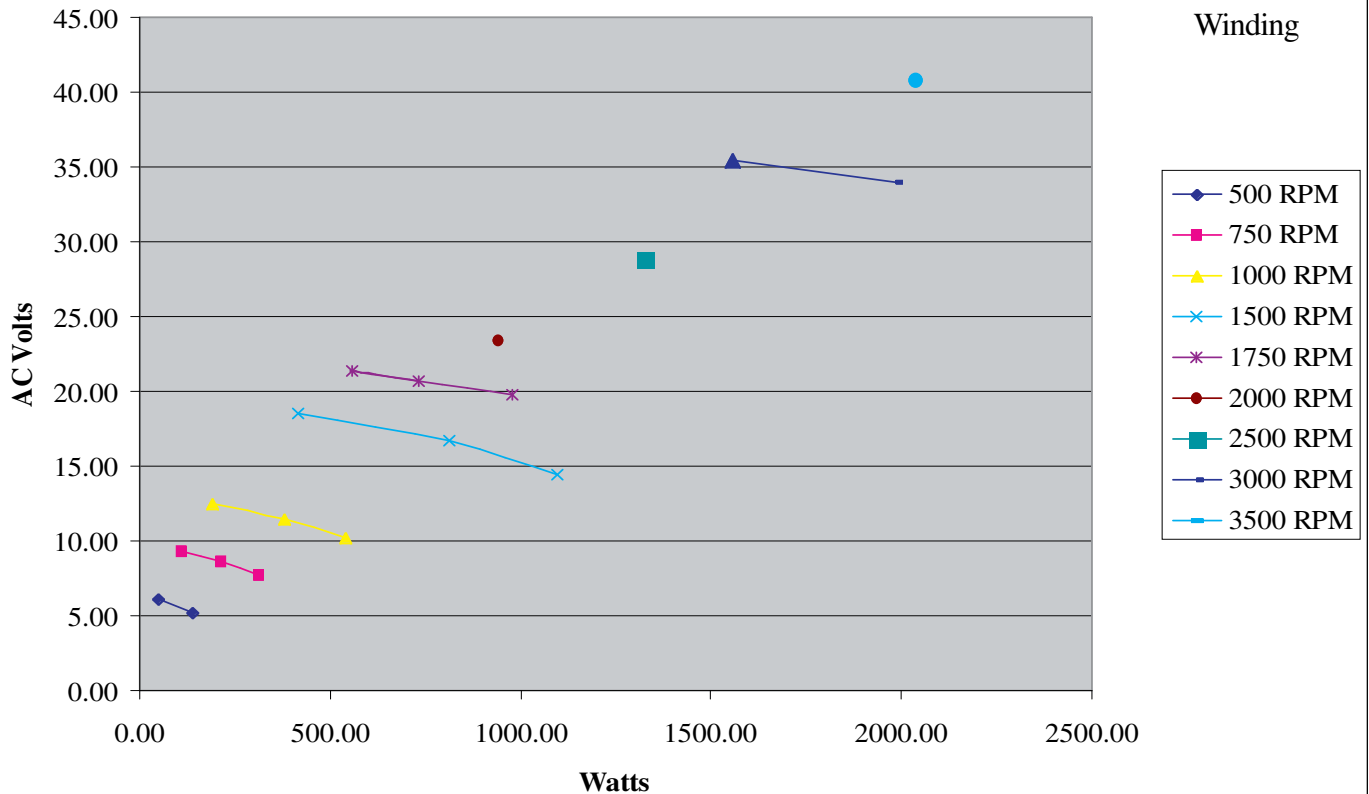

Mounting

Generally, the alternator mounts directly to the engine's prop shaft or rear output shaft. It can also be belt driven. The stator is kept from turning by a mounting bracket.

We machine the stator bracket specific to each engine model.

It is possible to mount the stator directly to a machined ring on the engine. This eliminates the bracket and the sealed ball bearing, reducing weight.

Engine load calculations before regulation

$Engine\ load = Output\ power / Efficiency.$

Example: A 600 Watt electrical load at 95% efficiency requires $600 / 0.95 = 632$ watts of engine power. At 746 Watts/HP, this is .847 HP.

$Ft-Lbs\ of\ Torque = Horsepower * 5252 / RPM.$

At 3000 RPM, a 600 Watt load at 95% efficiency will have a torque load of .847 HP * $5252 / 3000 = 1.483$ Ft-Lbs.

$1\ Ft-Lb = 1.3558\ N-M.$ 1.483 Ft-Lbs of torque is 2.010 N-M.

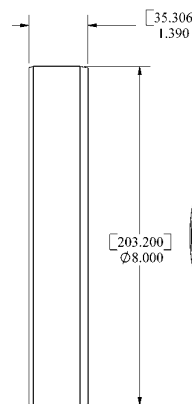

S675-800
Outline Drawing

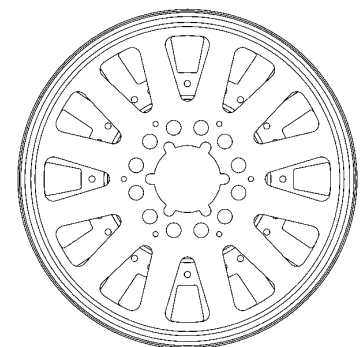

S675-800 on 3W-342
with rear mounted starter



1 North Haven Street
Baltimore, MD 21224
Phone 410-732-3500
fax 410-327-7443
www.sullivanproducts.com

Voltage Regulation

A wide range of voltage outputs are possible with these brushless alternators.

The incoming variable voltage/variable frequency AC input is rectified, filtered, and regulated to DC using switch mode regulation. Typically, these regulators are rated to +/- 0.2V with 200 mV ripple maximum. The actual specifications vary with output voltage, input range, and power. The outputs are filtered to 1 GHz.

The alternator's useful RPM range depends on the output voltage(s), circuit design, and components. The RPM range can be anywhere from 2:1 to 6:1. 3:1 is typical, and we can lay out custom designs and special winding regimens for high speed or low speed ranges.

The regulator boards are designed for the wattage the program needs, up to the limit of the alternator itself.

Some commonly requested regulator features are:

- External Power Connections (Service Cart)
- Backup Battery switching
- Status Signal (5V when regulator is delivering voltage)

Generally, the regulators are supplied in fan-cooled enclosures. However, they can also be supplied as open frame or without cooling fans if the application has adequate thermal management.

Some programs need only a single voltage (28V is most prevalent). Others need multiple voltages such as 28V, 12V and/or 6V. We can design the board for as many subsidiary voltages and wattages as required.

Nearly all systems use a backup battery for preflight or in case the engine stops. Often, we include a switching circuit that switches the battery into the main bus if the circuit senses that the alternator voltage is dropping. The advantage of this architecture is that a single backup battery can supply the main voltage and all of the subsidiary voltages.

It is also possible to design the system for multiple backup batteries.

The main voltage from these regulators is typically between 75% and 88% efficient. This varies by input voltage, output voltage and load. The alternator itself is between 95% and 97% efficient, so the overall system efficiency is usually 70% to 85%. Normally, subsidiary voltages are between 85% and 90% efficient after the main voltage output.

Engine load calculations after regulation

Engine load = Output power / Efficiency.

Example: A 150 Watt electrical load at 75% efficiency requires $150 / 0.75 = 200$ watts of engine power. At 746 Watts/HP, this is 0.268 HP.

*Ft-Lbs of Torque = Horsepower * 5252 / RPM.*

At 4000 RPM, a 150 Watt load at 75% efficiency will have a torque load of $0.268 \text{ HP} * 5252 / 4000 = 0.352 \text{ Ft-Lbs}$.

1 Ft-Lb = 1.3558 N-M. 0.352 Ft-Lbs of torque is 0.477 N-M.



700 Watt
28V Board

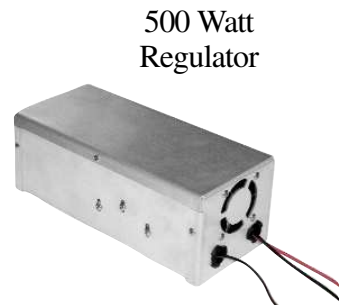

500 Watt
Regulator



500 Watt
Multiple
Voltage
Regulator

50 Watt
12V/6V
Board



Voltage Regulation

We make a series of standard regulator designs. However, since the power structure of many programs is specific to the vehicle, we lay out custom boards as needed. We can add circuitry for additional status signals, multiple inputs, multiple outputs, customer defined connectors, specialized backup schemes and unusual cooling requirements. The regulators are usually supplied with pigtail leads; however, we can use terminal blocks, quick connectors or Molex®-style connectors upon request.

We can also lay out boards to meet specific height and length restrictions, as long as we have enough total volume for the electronics and cooling.

The regulator boards are all solid state, except for the cooling fan. They have a design life well in excess of the engine and alternator. The boards have a mix of surface mount and through hole power components. For maximum reliability, we only fuse outputs if the customer requests. It is generally better to fuse individual loads so that a load failure does not disable the power system.

The electronics must be installed where there is adequate cooling air and where they will not get wet. We spray them after assembly with a conformal coating for protection from humidity.



500 Watt
Multiple
28V
Regulator



225 Watt
28V Board

300 Watt
28V Regulator

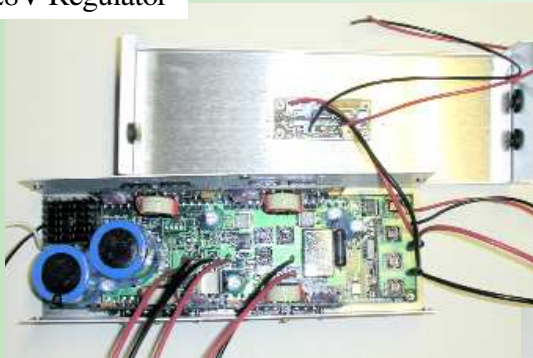

425 Watt
24V/12V/6V
Board

360 Watt 12V/6V
Regulator



150 Watt
Open Frame
12V/6V Board

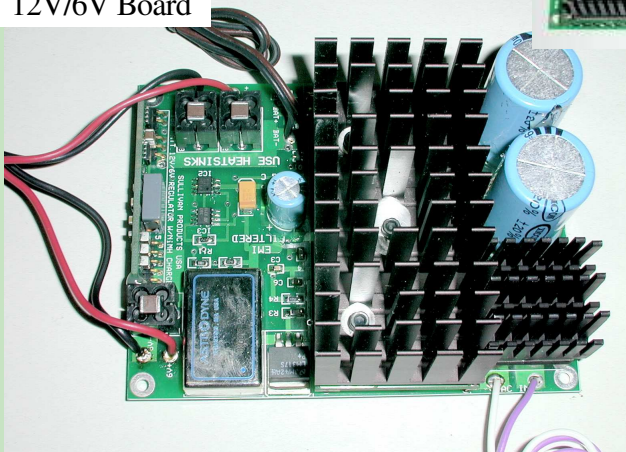

180 Watt 12V
Regulator

180 Watt
28V Regulator

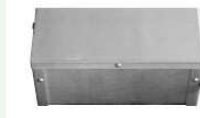

1 North Haven Street
Baltimore, MD 21224
Phone 410-732-3500
fax 410-327-7443
www.sullivanproducts.com